

The Munck Group of companies consists of several wholly owned manufacturing plants, subsidiaries, licensee manufacturers and service centres located in Norway and several countries throughout the world.

Munck has earned its reputation through 80 years of experience in designing and building cranes and hoists for the worldwide market. Today our products are marketed in over 60 countries and we are considered a leader in the industry.

Continuous research and development programs together with the highest engineering skills, combined with the most modern production techniques ensure a product line for the future. Our wide range of products is

offered through a widespread network of representatives and licensees backed up by after sales service and stock of spare parts locally.

Our standard range of cranes is built from our own designed, manufactured and proven modulated component program, providing maximum flexibility capable to suit most types of lifting applications.

This, under strict supervision and quality requirements from Munck, also allows us to produce the steel structure locally by our licensees utilizing drawings and ready-built hoists and components supplied by Munck to form the complete finished product.

Through our licensees and local sales offices we are able to offer complete turnkey installations

adapted to your specific needs.

Munck has always been a leader in the industry and has pioneered numerous developments which today have become standard for the crane and hoist industry.

We consider material handling something more than just moving a load from one point to another. Our expertise and technical know-how will present the most economical solution to the customers specific needs, without sacrificing quality, reliability and safety. Maintenance costs and need for spare parts must also be kept to a minimum.

We are totally committed to this business and backed by our 80 years of experience Munck is a safe choice for your future.

## MUNCK CRANES AS

KOKSTADVEGEN 30

SERVICE BOX 7130

N - 5020 BERGEN - NORWAY

TELEPHONE: + 47 55 59 80 00

TELEFAX : + 47 55 59 80 40

E-mail: [firmapost@munck-cranes.no](mailto:firmapost@munck-cranes.no)  
Web site: [www.munck-cranes.no](http://www.munck-cranes.no)

For further information, please contact:

## THE MUNCK WIRE ROPE HOISTS

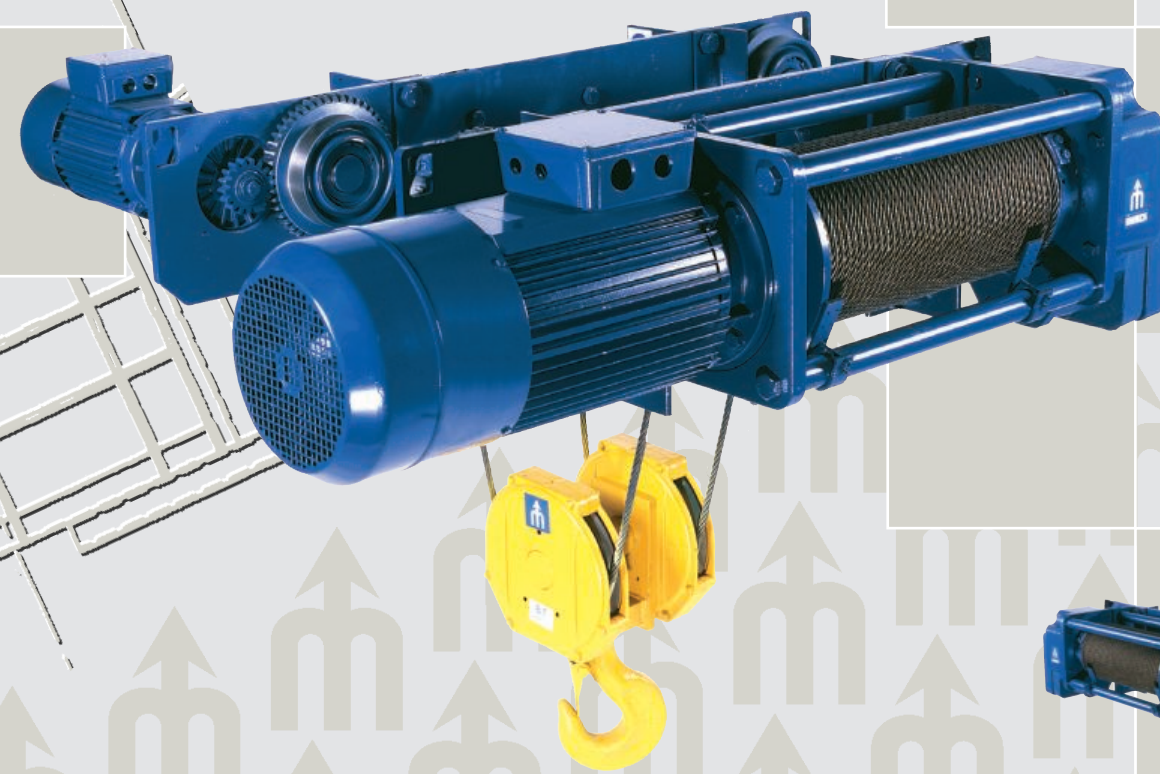

## 31-SERIES

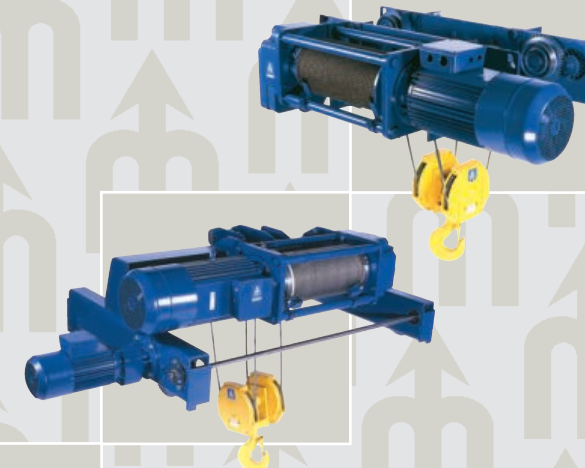

**munck**



**munck**





**L**ow headroom monorail hoists for maximum lifting height are used on MUNCK MONOBEAM cranes or monorails, and are available in a wide range up to 55 metric tons. The electrical cabinet is not integrated in the hoist and can, easily be located in the most convenient and safe place.

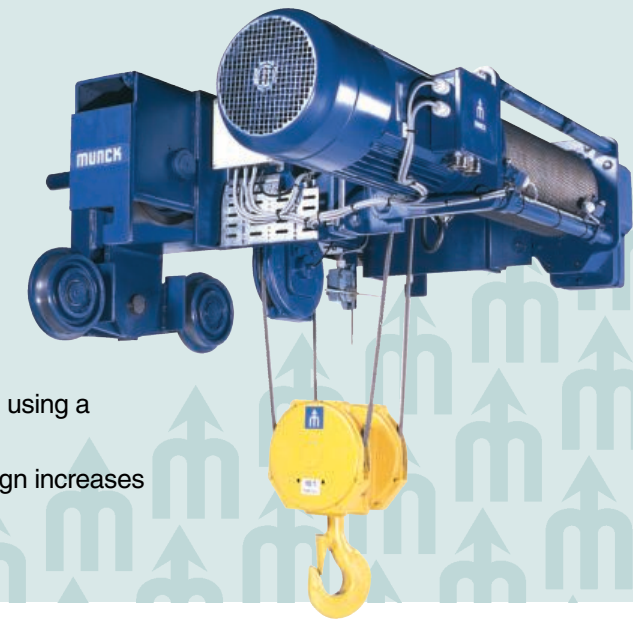

**A** smart solution to achieve better headroom using a top running trolley on a single girder crane. With larger span, the cost efficiency of this design increases



**T**he two-rail trolley permits maximum hook travel and is used on MUNCK DUOBEAM cranes. These are available in a standard range up to 108 metric tons and as a custom built hoist up to 500 metric tons.

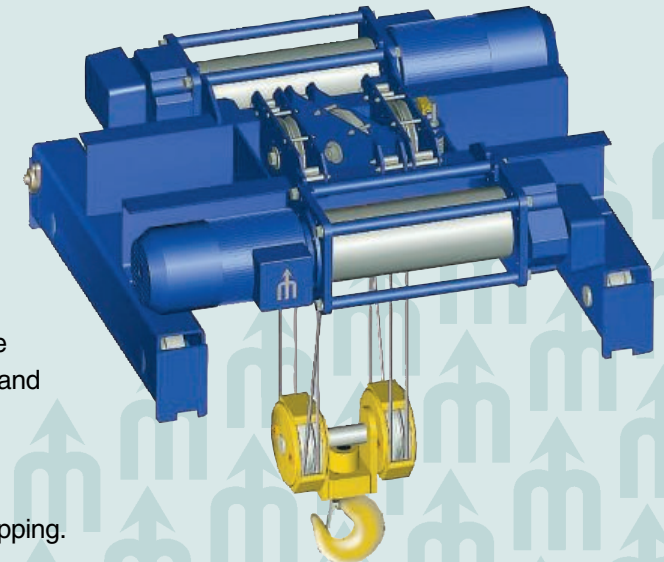

**T**win hoist have the same features as the single hoist two-rail trolley, but with double lifting height and lifting speed, and facilitates true vertical lift. This application is also available with both hoists operating independently and/or synchronized. This special feature will protect the load from dropping.



**A** universal, basic configuration that can be placed on a bearing surface, or suspended. The largest hoist model can lift up to 9 metric tons on a single fall of wire rope. Each hoist is available with any of 5 different hoist drums, providing a wide range of lifting heights.

## New generation hoisting

For nearly 80 years, MUNCK has manufactured hoists and other lifting equipment. The 31-series MUNCK hoists are specifically designed to meet the challenges of precision lifting material handling for the next decade.

MUNCK is well known worldwide as a quality brand. The new hoist range have been tested to the limit to ensure that we fulfill our high quality standards. All components comply fully with the latest international standards such as EN – NS, FEM, ISO, CMAA and HMI.

MUNCK's Product Development Department uses "I-deas", a world leading 3D-CAD program with integrated FEM-calculation module, to develop this new line of MUNCK products.

# COMPONENTS OF THE 31-SERIES HOIST

## OVERLOAD PROTECTION

All Munck 31-series hoists are fitted with either a mechanical or an electronic overload protection device. Munck's "safe-load" unit is available as an option to monitor the load spectrum.

## WIRE ROPE

Munck's wire rope is made of high strength, fatigue resistant and wear-proof flexible steel. The type of wire rope complies with the ISO 4308/1 standard.

## WIRE ROPE GUIDE

The wire rope guide is a mechanical device which provides constant pressure on the wire rope to ensure a positive engagement with the drum groove. This prevents overlapping of the wire rope and promotes longer wire rope lifetime. Munck's unique two-part system is designed for easy maintenance and durability.

## ROPE TERMINATION (DEAD END) SOCKET AND WEDGE

This component is made of nodular cast iron and conforms to FEM 9.661/86. The wire rope passes through a tapered socket and wraps around a wedge. The tension on the wire rope caused by lifting of a load forces the wire rope and wedge into the socket creating a positive mechanical termination, eliminating the need for wire rope clips. Once set, the rope is secure in the loaded and unloaded condition.

## TROLLEY DRIVE

The wheels are permanently lubricated and driven by a pole change motor. The motor is specially designed to give soft start and the ratio between creep speed and maximum speed is 1:4. Minimum two of the wheels are always motorized.

## FREQUENCY DRIVES

As an option, both hoist and trolley drive can be operated by means of a frequency converter. Acceleration and deceleration can each be adjusted so that swinging of the load, a known source of accidents, is largely eliminated. The high quality 4-pole motors are also suitable for overspeed drive with reduced load. The extra cost is justified by less wear and tear.

## GEARBOX

The 3 stage reduction unit is comprised of a self contained cast iron housing with heat treated, alloy steel, helical gears in oil bath. All gear shafts are supported on antifriction bearings. The gearbox is rated to a minimum design group of 2m/M5.

## ELECTRICAL CONTROL

Electrical controls (contactors, relays, etc.) are operated with a push button pendant station or a radio remote control unit. Inside the cabinet, you will find that every circuit has automatic fuses and all cables and components are clearly marked for easy identification. Each cable is connected directly to the external components.

## ROPE DRUM

The drum is made from a steel tube with precision-machined grooves that properly support the hoisting wire rope to ensure maximum wire rope life. Each end is supported by bearings housed in rugged steel end plates. The drum is designed to conform to ISO 4308/1 and FEM 9.661/86.

## HOOK BLOCK

The hook block sheaves are made of heavy cast iron with machined grooves rotating on sealed and lubricated for life ball bearings and are enclosed in protective guards. The hook complete with latch is forged from high strength steel and rotates on a thrust bearing. The hook complies with DIN 15 400.

## HOIST MOTOR

The Munck wire rope hoist is equipped with a heavy duty two speed polechanging squirrel cage motor that is fan cooled and designed for a minimum 2m/M5 duty cycle. The motor conforms to IP54 with class "F" insulation and has provision for thermal overloads.

## HOIST BRAKE

The DC rectified disc brake is an integral part of the hoist motor and is activated when the power to the hoist is terminated. The asbestos free brake linings are designed for 1 million brake operations. Under normal duty this brake is considered maintenance free requiring only inspection in accordance with local regulations.

## LIMIT SWITCHES

The limit switches are safety features that control over hoisting and over lowering by disconnecting power to the hoist motor. The switches are adjustable for your specific requirement. The device consists of two high-precision, slow-brake micro switches acting on the auxiliary circuit of the hoist motor control device.

**NOISE:** : The noise level of the hoist, when operating at maximum capacity under the heaviest operating conditions does not exceed 85 dB(A) in a distance of 1 m at any given time.

**STANDARDS** Munck's new 31-series hoists and their trolleys are designed to meet or exceed the latest international standards, including EN-NS, FEM, ISO, CMAA and HMI.

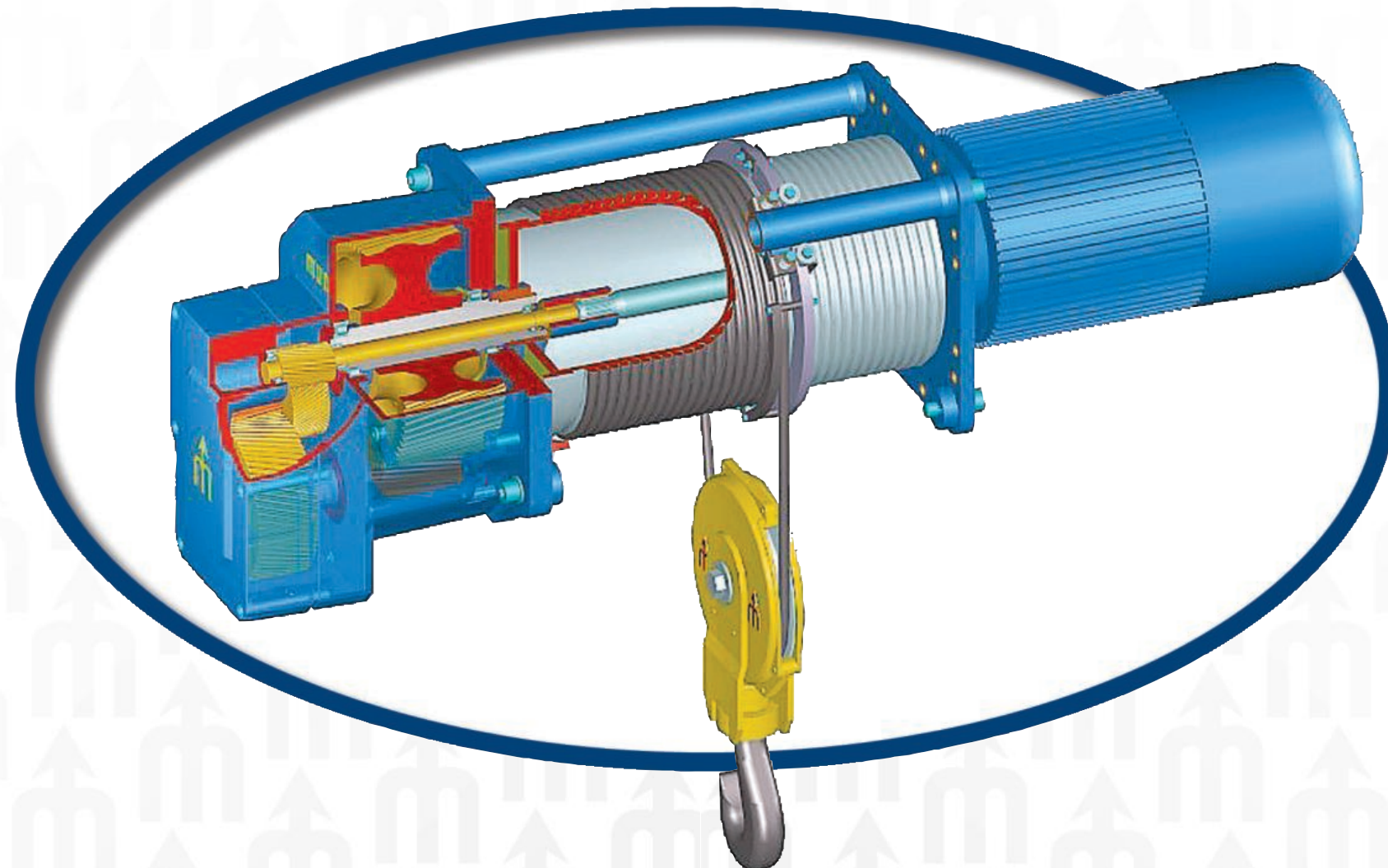



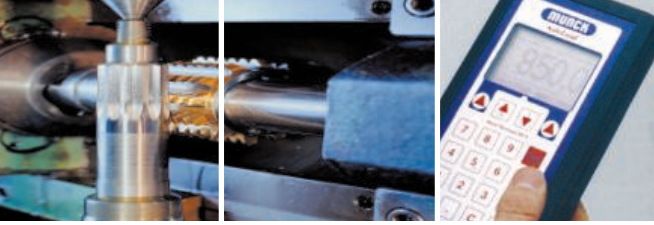

# The Munck hoist selection program

which will meet all your requirements

(Load capacity in kg)

HOIST TYPE	GROUP FEM/ISO							
		1/1	2/1	4/1	6/1	8/1	10/2	12/2
<b>3101/3201</b>	3m/M6	630	1250	2500				
	2m/M5	800	1600	3200				
	1Am/M4	800	1600	3200				
<b>3111/3211</b>	3m/M6	1000	2000	4000				
	2m/M5	1250	2500	5000				
	1Am/M4	1250	2500	5000				
<b>3121/3221</b>	3m/M6	1600	3200	6300		12500		
	2m/M5	2000	4000	8000		16000		
	1Am/M4	2000	4000	8000		16000		
<b>3122/3222</b>	3m/M6	2000	4000	8000		16000		
	2m/M5	2500	5000	10000		20000		
	1Am/M4	2500	5000	10000		20000		
<b>3131/3231</b>	3m/M6	2500	5000	10000	15000	20000		
	2m/M5	3200	7500	15000	20000	30000		
	1Am/M4	4000	8000	16000	25000	32000		
<b>3141/3241</b>	3m/M6	4000	8000	16000	25000	32000	40000	
	2m/M5	5000	10000	20000	30000	40000	50000	
	1Am/M4	5000	10000	20000	30000	40000	50000	
<b>3151/3251/3351</b>	3m/M6	5000	10000	20000	30000	40000	50000	60000
	2m/M5	6300	12500	25000	36000	50000	63000	75000
	1Am/M4	6300	12500	25000	36000	50000	63000	75000
<b>3161/3261/3361</b>	3m/M6	6300	12500	25000	36000	50000	63000	75000
	2m/M5	7500	15000	30000	45000	60000	75000	90000
	1Am/M4	8000	16000	32000	48000	63000	80000	96000
<b>3171/3271/3371</b>	2m/M5	8000	16000	32000	48000	63000	80000	96000
	1Am/M4	9000	17500	36000	54000	72000	90000	108000

## Standard FEATURES

- ⊕ Overload protection
- ⊕ Overheating protection of the motor
- ⊕ Dual speed hoisting
- ⊕ Munck unique heavy duty wire rope guide
- ⊕ Class "F" insulation motor
- ⊕ IP54 class protection
- ⊕ Time recorder (when electrics supplied).
- ⊕ Hoist and lower limit switches
- ⊕ Parallel rotor motors
- ⊕ Soft start travel drive
- ⊕ Hoist brake adjusted for life
- ⊕ Motors are duty rated according to machinery. grouping with the same rating on both full and slow speed.
- ⊕ All models available on CAD files.

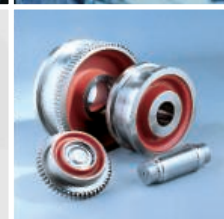
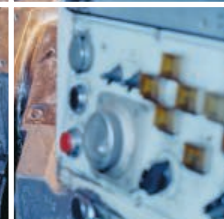
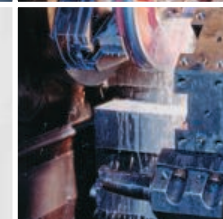
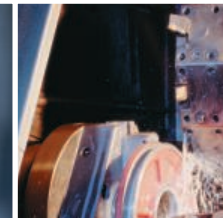
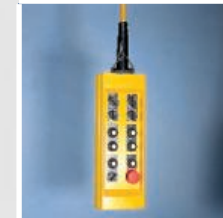

## ACCESSORIES

- for all your needs

- ⊕ Munck programable speed control on hoist (stepless or two selected speeds).
- ⊕ Munck programable speed control on trolley (stepless or two selected speeds).
- ⊕ Munck Safe Working Period recorder A16 or A30.
- ⊕ Munck digital load indicator display used together with A30
- ⊕ Overheating protection of the travel motor
- ⊕ Main contactor
- ⊕ Munck ultimate hoist limit switch (extra safety to prevent accidents).
- ⊕ Munck travel limit switch(es) -slow down and full stop
- ⊕ Anti-condensation heaters in hoist motor
- ⊕ Anti-condensation heaters in travel motor(s).
- ⊕ Munck standard radio control unit.
- ⊕ Sway control system. (Use in conjunction with programable speed control).
- ⊕ IP55 class protection of motors.
- ⊕ Hand release on hoist brake.

