



munck



MUNCK

QUALITY, SAFETY & VALUE

Munck Cranes offers a wide variety of cranes and material handling equipment limited by customers requirement only.

Munck Cranes has extensive experience as supplier of such equipment for the world market. Munck equipment has been manufactured and marketed for since the company was founded by Sverre Munck in 1924.

Today, Munck cranes, hoists and other types of lifting equipment is marketed in more than 70 countries. This equipment is used in the ship building, processing, steel and power generating industries – from Thailand to Ghana and from the Northern tip of Norway to New Zealand.

Munck also supplies lifting equipment for the offshore industry where the cranes are delivered to very strict specifications which meet the challenging lifting tasks and performance of this demanding industry.

Munck cranes are manufactured to meet or exceed all international crane norms and regulations.

The first Munck electric wire rope hoist was introduced in 1948 and was immediately recognized as a robust and reliable hoist. Munck has continued to acquire the necessary resources to be in the forefront of technological development.

The most valuable resource at Munck is their quality oriented staff. The engineers at Munck, carefully analyse the needs and requirements of their clients, they offer valuable advise and will – if needed – present tailor made solutions to meet these demands.

Muncks ability to provide turn-key installations allows our clients, time to concentrate their efforts to develop their company and its value to their customers.



MUNCK ELECTRIC WIRE ROPE HOIST

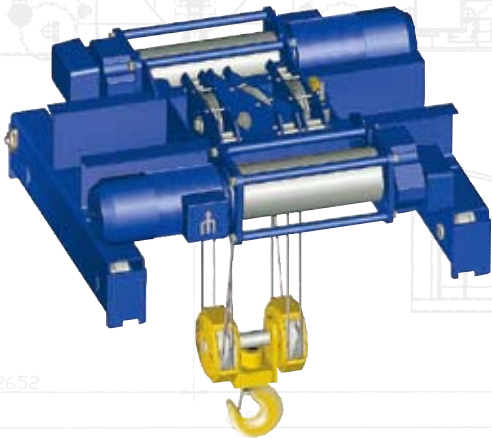

- Quality throughout

The latest Munck “31 series” hoist is a direct result of Munck's continuous product development efforts, which have resulted in a modern and flexible hoist unit. Typical to the Munck electric wire rope hoist is its robust design and limited need for service – two important factors resulting in low maintenance costs.



The Munck standard hoist range is more comprehensive than ever before, and covers lifting capacities from 630 kgs to 108 tons.

For special applications requiring different speeds and higher lifting capacities, Munck is able to tailor make solutions offering lifting capacities up to 500 tons. These units are also built up from high quality components offering the same economical advantages as the standard program.

During development and design Munck is constantly focusing on:

- Safety and ergonomics
- Thorough quality control routines
- Advanced analysing tools
- Tailor made designs and solutions
- Turn-key installations



MUNCK MONOBEAM CRANES

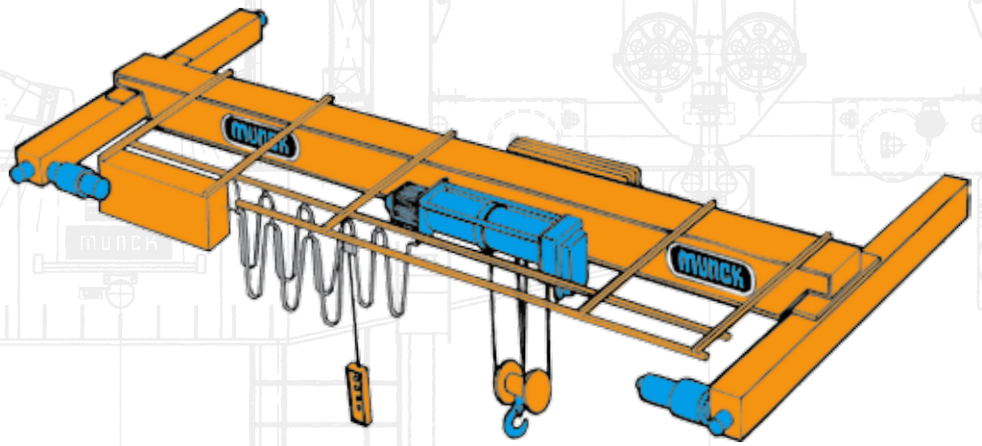

Munck Monobeam cranes are the most widely used, crane configuration supplied by Munck Cranes. The low headroom monorail trolley mounted on the single girder construction offers a compact design which will maximize high hook position with a crane that is both economical and reliable.

- Standard components that can be incorporated in custom applications
- State of the art crane design technology and modern fabrication techniques result in a product that achieves high quality in all applications.
- All motors are specified for crane and hoist duty with sizing and selection offering smooth operation
- Some of the available options that can be added to the standard monobeam crane include
 - Frequency drives for all motions
 - Radio remote control
 - Overload limiters for hoisting units
 - Travel limits for all motions
 - Electronic weighing systems and (SWP) recording units
- Contact your local Munck representative to discuss how a Munck Monobeam Crane System can be custom tailored for your application at competitive prices



MUNCK QUALITY AND DESIGN:

With several decades experience in providing lifting equipment that offers long life, low maintenance costs and reliability for all of your material handling applications.

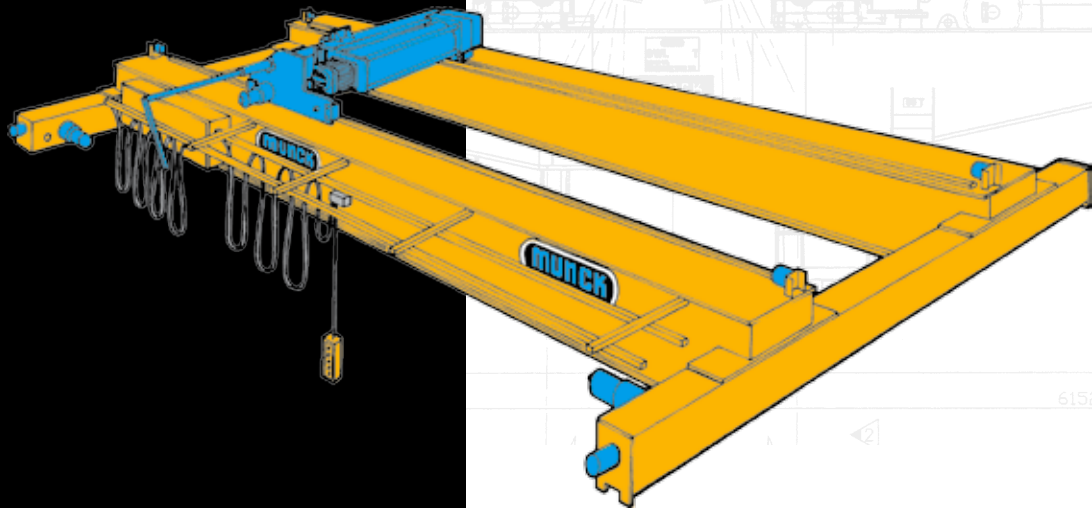

MUNCK DUOBOX CRANES

This crane design is the ideal solution in buildings where short headroom is important. Apart from being double girder design, the concept is very much like that of the monobeam design.

Application and optional equipment

It is rather simple to adapt Munck Duobox and Monobeam cranes to suit any special handling requirement and/or any local government rules and regulations.

All Munck cranes can be supplied with a wide range of optional equipment, some of which are:

- Cross and long travel limit switches
- Anti collision system
- Service platforms
- Walkways
- Electronic weighing device
- Life span and load registering devices
- Stepless control of all motions
- Remote control systems, radio or infra red
- Vacuum equipment
- Magnet system
- Lifting yoke
- Safety warning devices (audio/visual)
- Other safety equipment which may be called for

And also:

- Crane runways, rails and downshop electrical supply systems





MATERIAL HANDLING EQUIPMENT - AUTOMATION

Within the Munck organization is a separate project and engineering department which is heavily engaged in identifying and carrying out projects in all sectors of material handling, using the most advanced computerized design equipment, tools and design

techniques. This department is staffed by highly qualified engineers having extensive experience within the field of material handling. Upgrading, refurbishing and automating of existing crane installations is also among Muncks specialities.

Some of the equipment included in Muncks scope of supply:



Automatic crane systems for the process industry:

- Grab cranes for various applications
- Cranes for use in the aluminium industry (electrolyte and anode handling cranes)

Special cranes

- Magnet cranes
- Cranes equipped with fixed or telescopic masts
- Goliath cranes
- Cranes for heavy industries
- Cranes for the power generating industry
- Cranes for the pulp and paper industry
- Cranes used in the fishing industry (net handling)

Other special components/options for various lifting applications

- Lifting clamps
- Lifting yokes for container handling and others
- Grabs
- Magnet yokes
- Cable drums
- Rail clamps

MUNCK LIGHT WEIGHT SYSTEM

Munck chain hoists represent an excellent and economical solution for lifting lighter loads. The chain hoists are available for different lifting capacities, and are available both as manual or as electrically operated.



The Munck comprehensive light weight system program includes:

- Chain hoists
- Vacuum lifters
- Runway systems
- Jib cranes

Vacuum system offers ergonomic solutions for light and frequent lifts, which otherwise would be done manually. The system is rather simple, which incorporates a vacuum pump, a filter, suction hoses and vacuum unit adapted to the specific load to be lifted - «Vacuum system makes the air do the job».

Munck lightweight system can be adapted as monorails as well as crane applications, serving larger floor areas, or as Jib-cranes.

Munck system offers a considerable degree of flexibility used in combination with the Munck chain hoists and trolleys. The vacuum system is also used in combination with and suspended from the Munck light weight system.



Munck Cranes as
Kokstadvegen 30
P.O. BOX 7130
NO - 5020 Bergen - Norway

Telephone: + 47 55 59 80 00
Telefax: + 47 55 59 80 40

E-mail: firmapost@munck-cranes.no
Website: www.munck-cranes.no